



TECHNOLOGIES

**CLEANROOM
FURNITURE**

Product Datasheet

Modular Workstations (OMC1022)

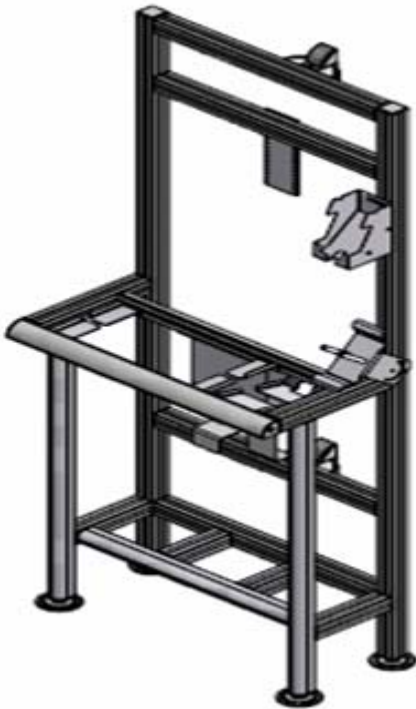

OMC manufacture a range of both mobile and fixed computer workstation for the cleanroom industry constructed from Bosch Aluminium Framing

Features:

- Agent for Bosch Framing systems
- Fully set up fabrication shop for assembly of these units.
- All units are fully modular and can be integrated into existing units on site or broken down and re formed with minimal wastage.
- All aluminium panels are clear anodised prior to shipping to cleanroom.

Construction:

- Panels punched on Trunpf 5000 CNC punching centre
- Hydraulic press formed with LVD Pressbrake CNC controlled
- TIG welded
- All welds ground and polished to 240grit finish
- Clear anodized to cleanroom specification

Material:

- 45 x 45 heavy duty bosch square profile
- Fasteners and connection kits as required

Dimensions:

- Units come in 600, 950, 1200 and 1500 series wide

OMC Technologies Limited
Ballysimon Road,
Limerick
Ireland

Tel: +353 61 419333
Fax: +353 61 418644
E-Mail: sales@cleanroomfurniture.ie
Web: www.cleanroomfurniture.ie